



US00D460787S

(12) **United States Design Patent**
Nishikawa

(10) **Patent No.:** **US D460,787 S**

(45) **Date of Patent:** **** Jul. 23, 2002**

- (54) **ELECTRONIC GAME MACHINE**
- (75) Inventor: **Yoshitaka Nishikawa, Kyoto (JP)**
- (73) Assignee: **Nintendo Co., Ltd., Kyoto (JP)**
- (**) Term: **14 Years**

D400,596 S	*	11/1998	Keung et al.	D21/329
D407,762 S		4/1999	Ota		
D417,291 S		11/1999	Sugino		
D421,775 S	*	3/2000	Goto	D21/329
D429,287 S	*	8/2000	Nara et al.	D21/329
D437,002 S	*	1/2001	Wudtke et al.	D21/329
6,227,966 B1	*	5/2001	Yokoi	463/1

- (21) Appl. No.: **29/142,642**
- (22) Filed: **May 31, 2001**

* cited by examiner

Primary Examiner—Prabhakar Deshmukh
(74) *Attorney, Agent, or Firm*—Nixon & Vanderhye PC

(30) **Foreign Application Priority Data**

Dec. 4, 2000 (JP)	2000-034598
Dec. 4, 2000 (JP)	2000-034599
Dec. 4, 2000 (JP)	2000-034600
Dec. 4, 2000 (JP)	2000-034603

(57) **CLAIM**

The ornamental design for an electronic game machine, as shown and described.

- (51) **LOC (7) Cl.** **21-01**
- (52) **U.S. Cl.** **D21/329**
- (58) **Field of Search** D21/324, 329,
D21/330, 331; 463/1, 29-35, 46, 47; 273/148;
345/905

DESCRIPTION

FIG. 1 is a front, right and top perspective view of a first embodiment of an electronic game machine showing my new design;
 FIG. 2 is a front elevational view thereof;
 FIG. 3 is a rear elevational view thereof;
 FIG. 4 is a top plan view thereof;
 FIG. 5 is a bottom plan view thereof;
 FIG. 6 is a left side view thereof;
 FIG. 7 is a right side view thereof;
 FIG. 8 is a front elevational view of a second embodiment of an electronic game machine;
 FIG. 9 is a rear elevational view thereof;
 FIG. 10 is a top plan view thereof;
 FIG. 11 is a bottom plan view thereof;
 FIG. 12 is a left side view thereof; and,
 FIG. 13 is a right side view thereof.

(56) **References Cited**

U.S. PATENT DOCUMENTS

D318,884 S	8/1991	Kojo	
5,046,739 A	* 9/1991	Reichow 273/148 B
5,184,830 A	* 2/1993	Okada et al. 463/46
D347,246 S	* 5/1994	Wen D21/329
D347,450 S	5/1994	Nagata	
D361,602 S	8/1995	Lee	
5,476,261 A	* 12/1995	Hustrand 273/148 B
D380,501 S	7/1997	Osterhout	
D383,798 S	9/1997	Yokoi	
5,672,108 A	* 9/1997	Lam et al. 463/2
D384,980 S	10/1997	Willems	

1 Claim, 7 Drawing Sheets

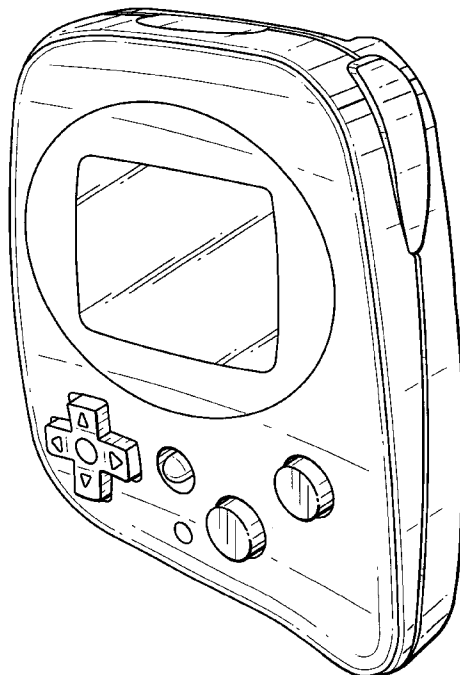

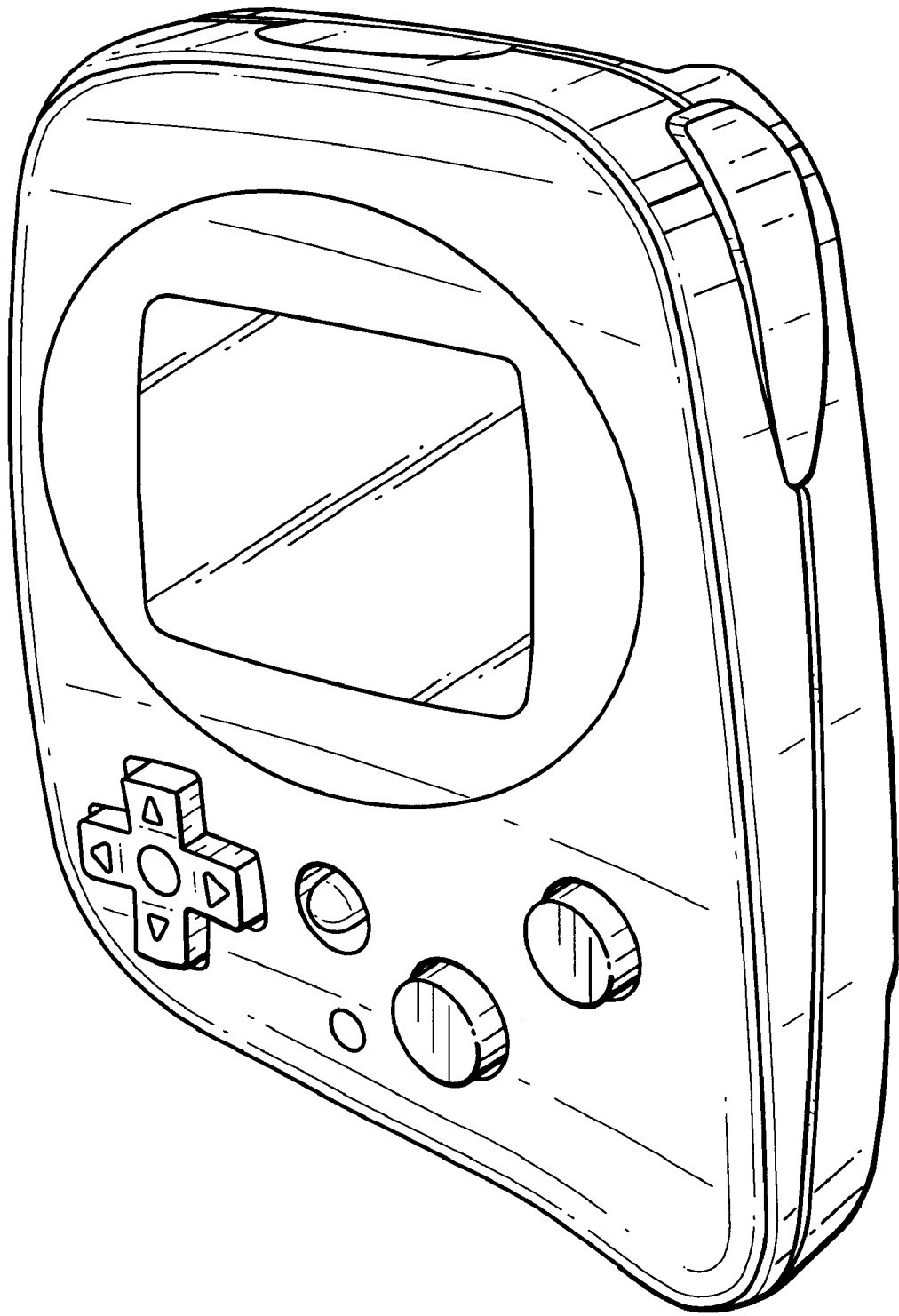

Fig. 1

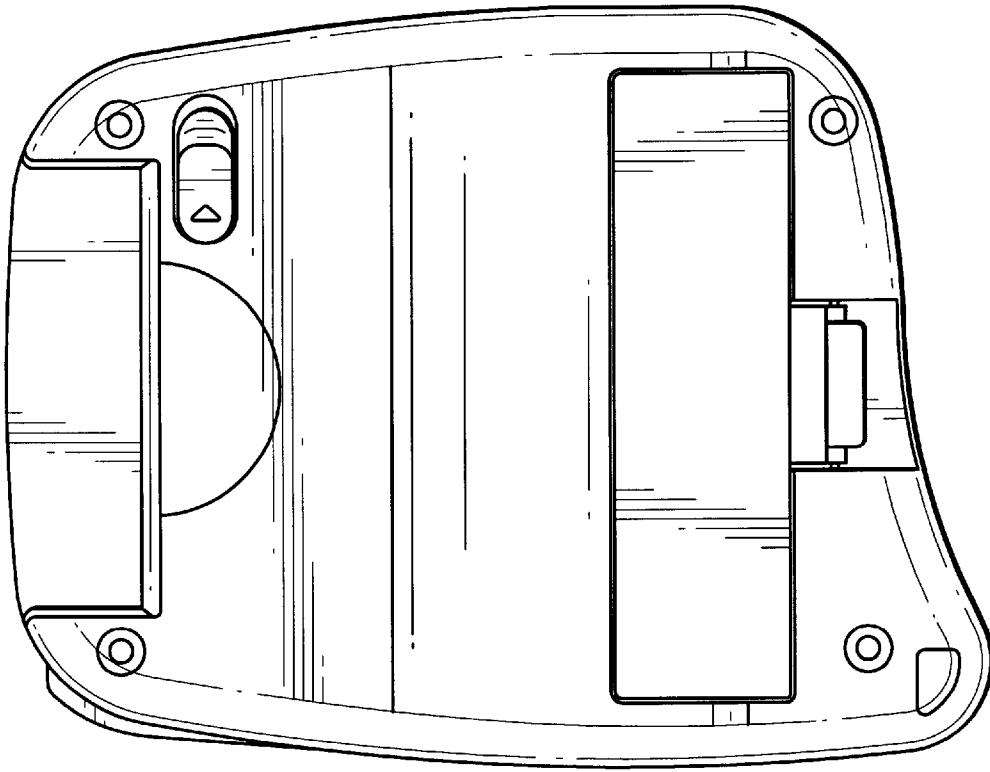

Fig. 3

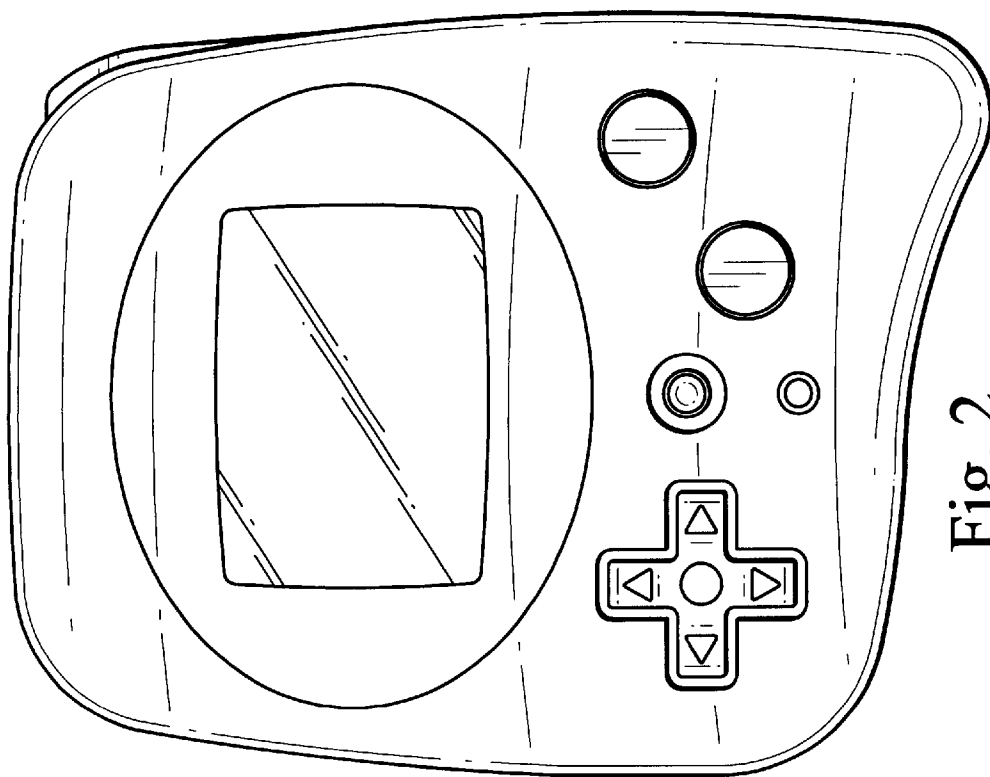

Fig. 2

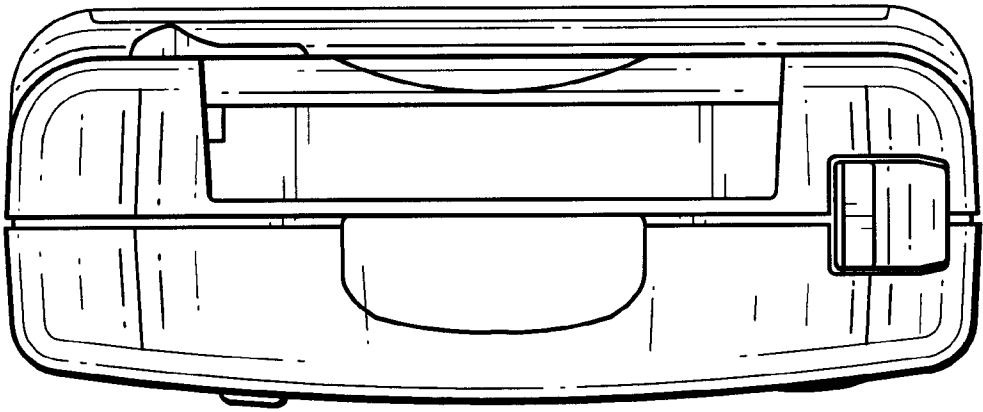

Fig. 4

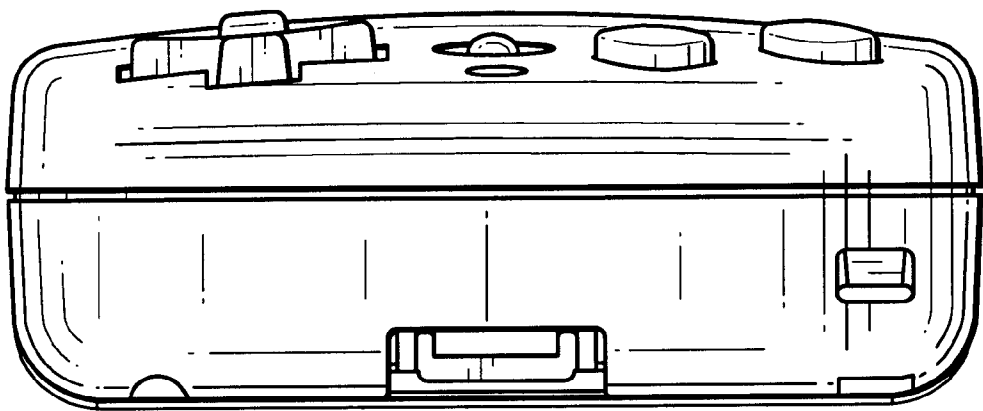

Fig. 5

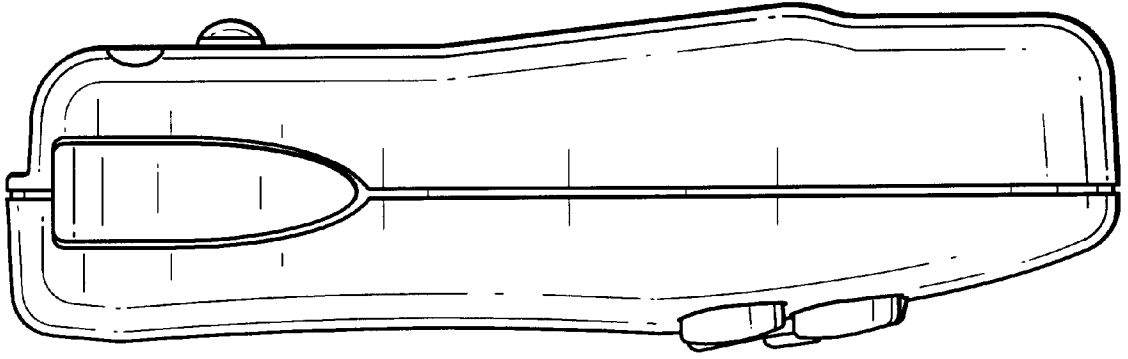

Fig. 7

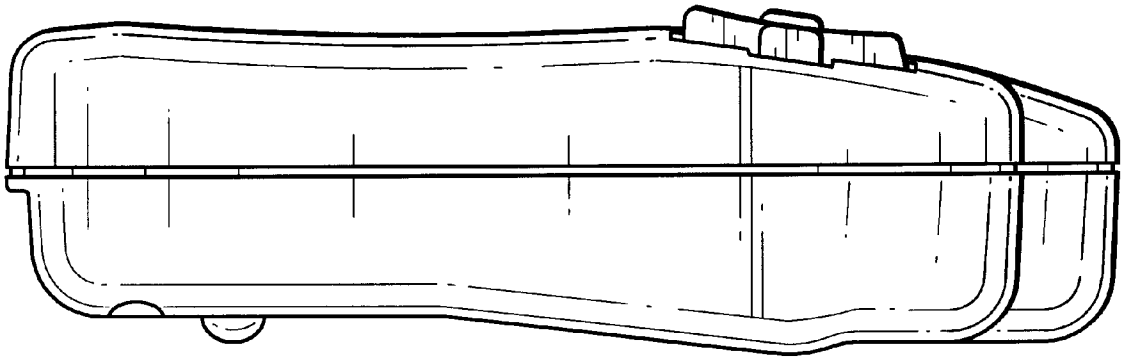

Fig. 6

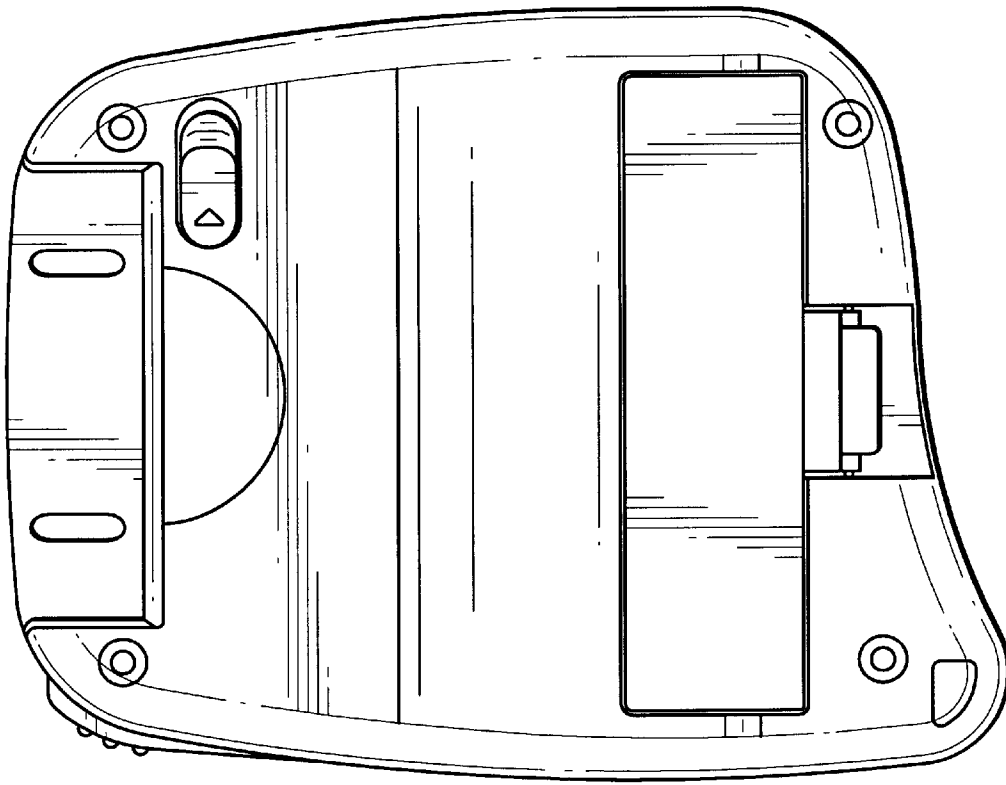

Fig. 9

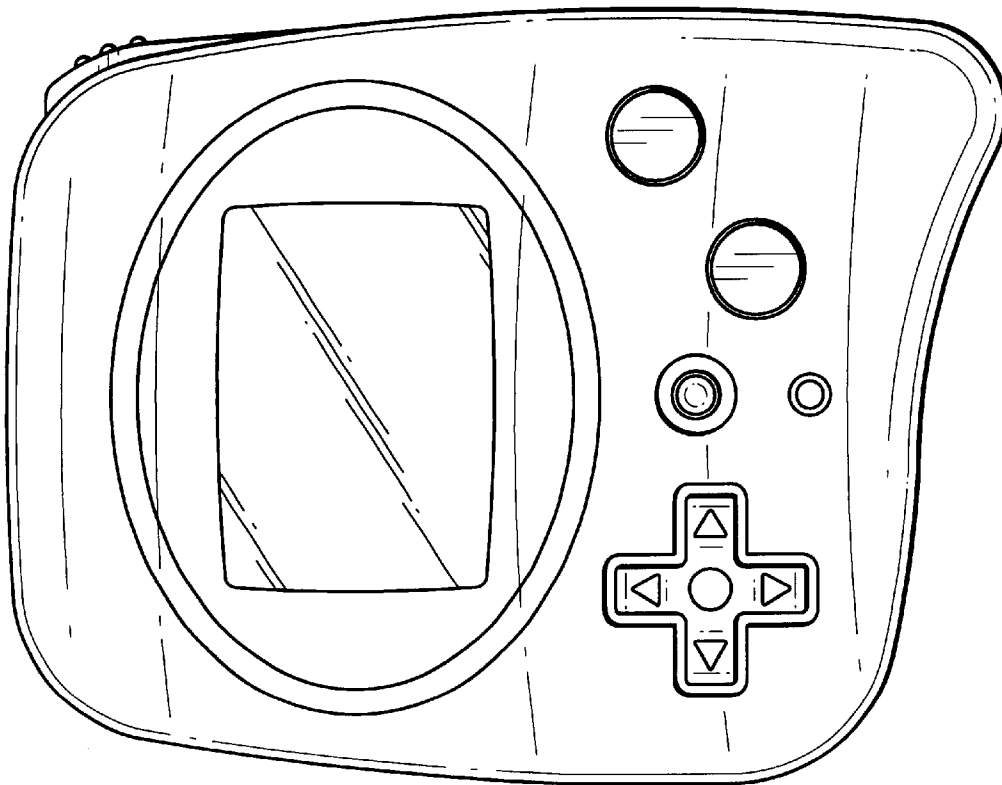

Fig. 8

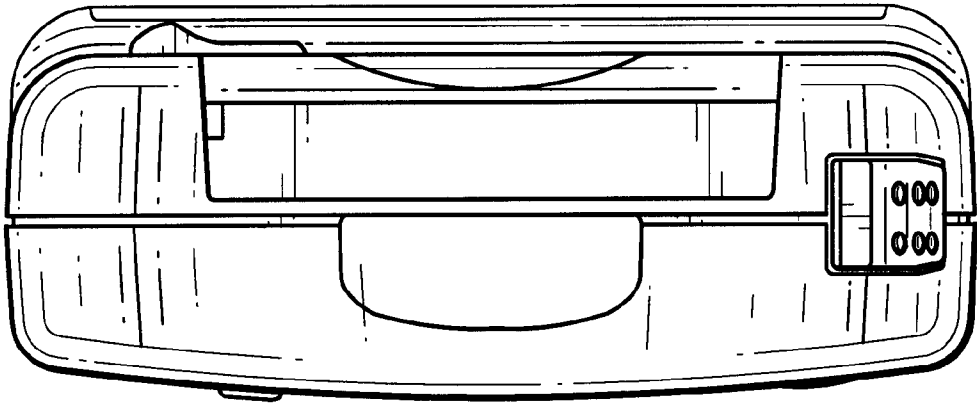

Fig. 10

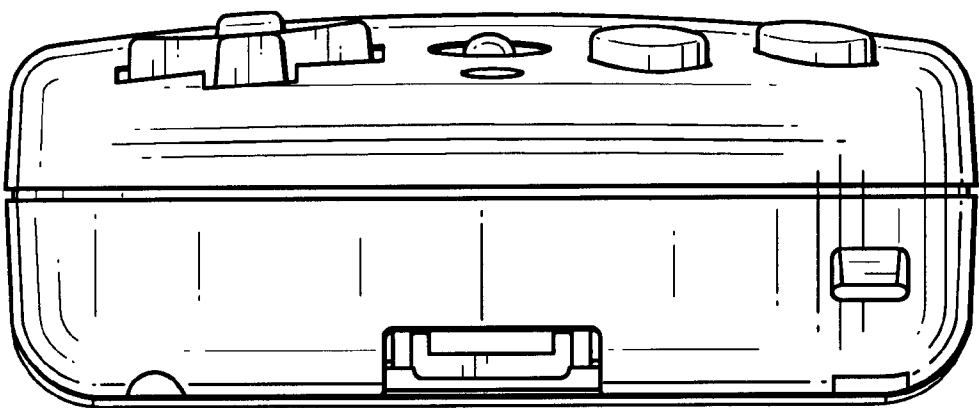

Fig. 11

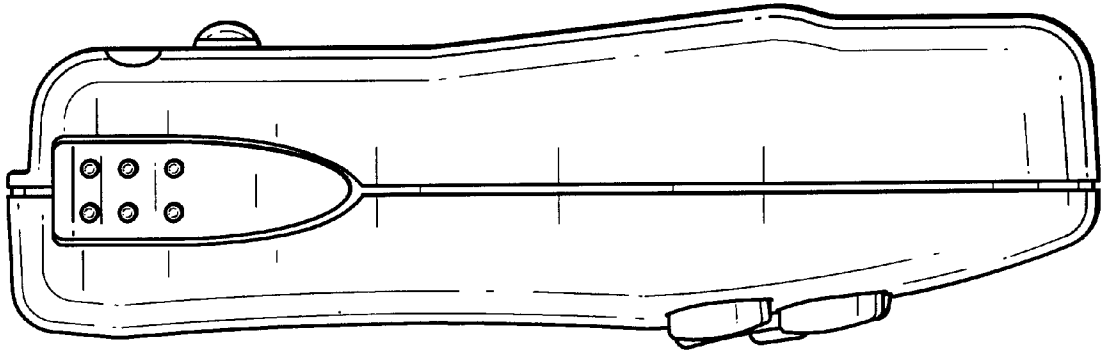

Fig. 13

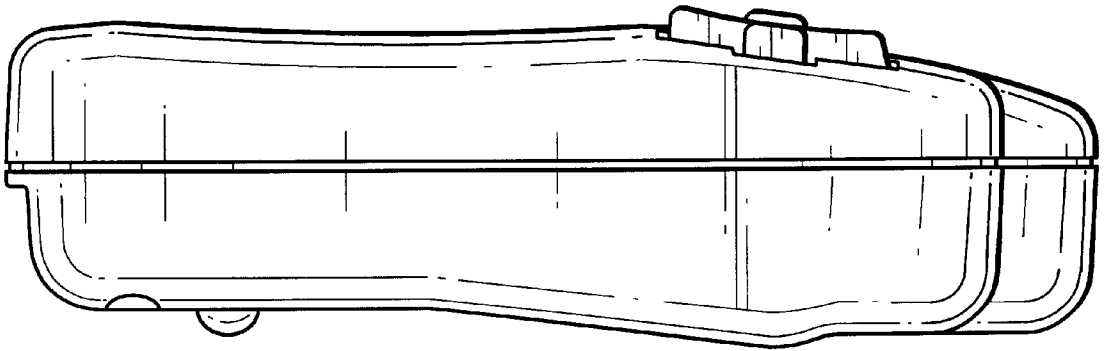

Fig. 12